



### Photovoltaic Solar Panels

Photovoltaic panels convert sunlight into electrical energy. Running your home off solar energy involves a significant financial outlay to begin with, but there are substantial rebates now available, and you will be rewarded with low or no electricity bills and the knowledge that your solar domestic electricity consumption is not creating any greenhouse gas emissions!

#### Energy efficiency

Solar power suits an energy efficient lifestyle. Reducing energy consumption reduces the number of required solar panels and thereby the cost. There are three appliances that can be hard work for solar panels, because they use higher levels of electrical energy. These are:

- any form of electric heating
- electric hot water
- electric stoves.

This means that solar panels can generally contribute to about 30% of the total electricity needs of the average household. You will therefore need to consider other energy sources for heating, cooking and water heating, such as gas, wood-fired heating or solar hot water heating if you don't have access to the electricity grid. To help reduce energy consumption in your home, download our Home Energy Audit Guide

<http://www.tasmanianenvironmentcentre.org.au/HomeEnergyDec07.pdf.pdf>.

Remember, solar power suits an energy efficient lifestyle, so ensure that your home is as energy efficient as possible BEFORE considering going solar.

In order for your solar system to provide enough energy to drive your other electrical appliances, you will need to know your average daily energy consumption, so that the correct amount of

panels and the correct battery capacity can be calculated. Electrical energy is measured in units of watthours (Wh) or kilowatthours (kWh). 1 kWh = 1000 Wh. There are two ways that you can determine your average daily energy consumption; you can determine the energy consumed by each appliance and add them together, or if you are connected to mains power then your daily average is given at the end of your electricity bill. If you want to determine the energy consumption of an appliance, measured in Wh, then you multiply the power rating in watts (W) by the time used per day in hours (h). For example a 200 watt appliance that runs for 3 hours will consume 600 Wh of energy. Alternatively you can measure the energy consumption of any appliance by buying or hiring a power meter, which you plug into a power point and then plug the appliance into it. Note: the national average daily energy consumption is about 18 KWH and the Tasmanian average daily energy consumption is about 25 KWH.

There are two ways that energy obtained from solar panels can be used. It can be fed into the mains electricity supply (**grid-feed systems**), or stored as electric charge in batteries and used at a later date when it is needed (**stand-alone systems**).

#### Grid-Feed Systems

In a grid feed system, an array of solar panels is used to generate electricity at 48-400v DC. This DC electricity is fed into a grid-feed inverter which converts the DC from the panel into 240v AC, at the same frequency and phase as the mains power and then feeds this electricity into the mains power grid.

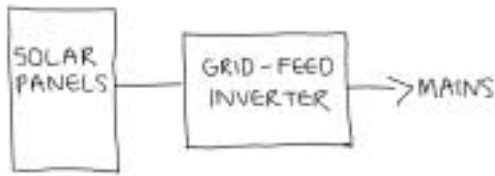

Tasmania uses a 'net' metering system. Your Authorised Electrical Contractor must apply to have a digital meter connected that will measure both the energy that you consume from the grid and the energy that you generate and feed into the grid. The meter will display both readings for you to view. You will be credited at the same price as you will be debited at for the tariff you are using. If you generate a surplus, you will receive a credit on your account for that amount calculated at the full tariff rate. Some states are adopting feed-in tariffs which means you get credited at a higher rate than you get debited at, thereby providing a financial incentive. Feed-in tariffs are provided by the local relevant network service provider and replace the previous retailer provider arrangements.

The advantage of grid-feed systems is that you don't need batteries, so they are cheaper. The disadvantage is that if the grid fails, the grid-feed inverter will not produce any electricity, even if the panels are in brilliant sunshine, so you will not have electricity until the grid is back up. However, if you live in an area that experiences frequent power outages or have an extremely important load you can overcome this by using a special type of grid-feed inverter which can run off a battery bank if the grid fails. Contact suppliers for more information on this option.

The largest array of solar panels that you can normally feed into the grid in Tasmania is 3KW, although Aurora will consider requests for larger systems. The average cost of a 1KW grid-feed solar

system will be about \$14,000 installed and will qualify for a \$8,000 rebate.

## Stand-Alone Systems

Stand-alone systems can provide electricity to houses that are not connected to the grid. Solar panels are rarely used to drive electrical appliances directly since they only produce maximum output during the middle of the day, and produce no output during the night, which is when most of our domestic electricity consumption occurs. So in stand-alone systems the electricity is stored in batteries. A voltage regulator is needed between the solar panels and the batteries to ensure the panels do not overcharge and ruin the batteries. The batteries are used to power electrical appliances, either DC or AC. If the appliances are DC ones they can be powered directly off the battery, via a fuse or circuit breaker. If the appliances are 240v AC ones then a stand-alone inverter will also be needed. The inverter converts 12v or 24v or 48v DC into 240v AC.

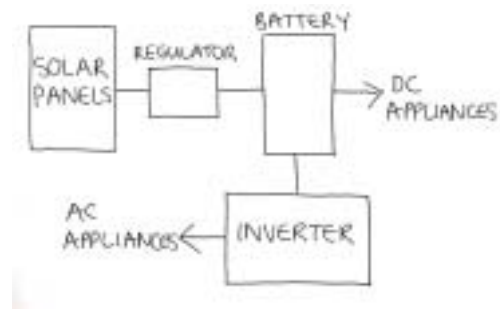

Generators and battery chargers can also be used to charge the batteries when there is a lack of sunshine for a protracted period.

Stand-alone systems cost roughly \$7,000 per KW. The solar panels and batteries will account for about 90% of the total cost of the system, with solar panels making up about 55% of the total cost and batteries about 35%.

Hybrid systems, which are a combination of solar panels, wind turbines and water turbines, can be used to make efficient, balanced system. Solar panels can have three times as much output in the summer as they do in winter, in Tasmania, due to the extra

daylight hours and stronger sunlight. However, in the winter there is usually more wind and rain and hence turbines can be more effective at this time of year, if you have strong reliable wind or access to a good river flow.

## Solar Panels

All solar panels currently sold in Australia are made out of silicon and most of them are imported. There are three types of silicon panels: polycrystalline, monocrystalline and thin film amorphous panels. The thin film panels have superior shade tolerance to the crystalline panels and use far less silicon, so they should become cheaper than crystalline panels. Origin plans to begin manufacturing solar panels made out of slivers of silicon. Like the thin film panels these also use less silicon than the crystalline panels and are reputed to have much better shade tolerance than any of the other panels.

Solar panels with a power output up to 130 W are made using 36 cells and have a voltage output of about 17v, under load. Solar panels with a power output greater than this are made using 72 cells and have a voltage output of about 34v, under load. The output current of a panel varies from about 0.1A to 7.5A depending on the power output of the panel and the strength of the sunlight. The efficiency of most solar panels is 12-17% but this will eventually double. Solar panels with efficiencies up to 35% have been made but they are not yet commercially available due to their cost. Solar panels are usually guaranteed for 20 or 25 years and have a lifespan of 30-40 years. They usually recover their embodied energy within 2-4 years.

You can make substantial savings on solar panels by forming a small group of people and buying in bulk. The retail cost of solar panels is about \$9 per watt, the dealer's price is about \$7 per watt and the distributor's price is about \$5.50 per watt.

If you buy in bulk you should be able to buy panels for about \$7 per watt. To buy them any cheaper you will need to buy them by the container load, which will require a large group of people. The Asian and European manufacturers are now starting to manufacture solar panels in larger and larger numbers, so it is expected that this will reduce the price of solar panels to a fifth of their current cost over the next decade.

## Power Output

Solar panels should face as close as possible to true north (within 15 degrees). There is an optimum angle of tilt from the horizontal that they should be mounted at, to obtain maximum energy output. This angle varies with the time of the year and is given in the following table.

### Season Optimum tilt angle (in degrees)

Winter Latitude + 23.5 = 67

Aut/Spring Latitude = 43

Summer Latitude - 23.5 = 20

Solar panels have several voltage and current ratings, but the current at maximum power, Imp (measured in A), is used to determine their output. The output varies depending on the angle of tilt and the length of the daylight hours. The output of a panel for the previous optimum angle of tilt is given in the following table.

### Season Output in Ah (per day)

Winter Imp x 3.1

Aut/Spring Imp x 4.9

Summer Imp x 6.5

## Inverters

Under no circumstances should an inverter that has been designed to be used in a stand-alone system, be connected to the grid. This would result in immediate and permanent damage to the inverter. Only certified grid-feed inverters should be connected to the grid. For a list of certified inverters see the Business Council – Sustainable Energy web site <http://BCSE.org.au/>. Grid-feed inverters

that can be used with a battery backup are made by Selectronic and Xantrex, and examples of those not designed to be used with a battery backup are made by Fronius, Latronics and SEA. BP Solar and Sunny Boy are SMA inverters. You can use a larger grid-feed inverter than you currently need, if you want to add more solar panels at a later date, ie. you can buy a 2 or 3KW grid-feed inverter and 1KW of solar panels and then add more solar panels at some time in the future. Alternatively you can increase the capacity of your grid-feed system by buying a second grid-feed inverter with more panels and running the two grid-feed inverters in parallel. Inverters will usually have a 5 to 10 year warranty but will have a lifespan of around 15 years.

## Batteries

Lead acid batteries are still the main type of battery used in solar systems. There are other types of batteries such as Nickel Cadmium, Nickel Metal Hydride and Lithium which are lighter, more compact and more robust than lead acid batteries, but are usually at least 10 times the price. Solar system batteries are designed to deep cycle whereas car batteries are not. Although car batteries will work in a solar system and will be cheaper than deep cycle solar batteries they will not last as long as solar batteries. A high quality solar battery will last 10 to 15 years. One of the biggest problems with solar batteries is using a battery bank that is too small, which leads to premature failure of the batteries. The minimum size battery bank is usually 10.5 times the average daily load. New batteries should not be placed in the same battery bank as old batteries since this will lead to a shortening of the lifespan of the new batteries. In low voltage systems the wiring is critical. There is a need to keep the voltage drop along the cables to less than 5% of the system voltage. The only way to achieve this by using the correct

size cable. The larger the diameter of the cable, the lower the voltage drop along it.

## Rebates

There are two Federal Government rebates available:

**Renewable Remote Power Generation Program:** To qualify for this rebate program you have to be at least 1km from the nearest mains electricity supply and have never been connected to it, or it would cost at least \$30,000 to become connected. The rebate is 50% of the total cost of the installed system. The Residential and Medium-scale sub-program provides rebates for households, communities, not-for-profit, business, government and other organisations. For further info and application forms contact the Office of Energy Planning and Conservation in the Dept of Infrastructure, Energy and Resources. Ph. 1800 105 688 [remote.power@dier.tas.gov.au](mailto:remote.power@dier.tas.gov.au)

<http://www.environment.gov.au/settlements/renewable/rrpgp/>

**Solar Homes and Communities Plan:** This is a rebate on solar panels only, returning \$8 per watt of installed solar panels, capped at \$8,000. Extensions to existing systems can return a rebate of \$5 per watt, capped at \$5,000, if you did not receive a rebate on the original panels. The conditions are that there must be at least 450 watts of installed new solar panels, which must be installed by an accredited installer and it only applies to places of principle residence. This rebate is also now means tested, making available to households earning less than \$100,000. More detailed information on eligibility requirements can be found at [www.environment.gov.au/settlements/renewable/pv/index.html](http://www.environment.gov.au/settlements/renewable/pv/index.html)

The National Solar Schools Program offers grants of up to \$50,000 (GST exclusive) to install solar and other renewable power systems, solar hot water systems, rainwater tanks and a range of energy efficiency measures. More info is available at,

<http://www.environment.gov.au/settlements/renewable/nationalsolarschools/index.html>

Grants are also available to community organisations that install photovoltaic systems where there is significant educational value. The competitive grants cover 50% of the system cost up to 2kW. Guidelines and application forms are available to be downloaded from <http://www.environment.gov.au/settlements/renewable/pv/index.html>.

For further information and application forms see the Department of Environment, Water, Heritage and the Arts Ph 1300 138 122

<http://www.environment.gov.au/rebates/>

**Renewable Energy Certificates:** A REC is generated for each 1MWh of renewable electricity generated. The Office of the Renewable Energy Regulator (ORER) determines how many RECs are issued to each solar system. In Tasmania the number of RECs that you can earn for a solar system, in a year, are the installed power output of the solar panel array measured in KW, multiplied by the number 1.185 and rounded down to the nearest whole number. So, for example, a 1 KW solar system would earn  $1 \times 1.185 = 1$  REC per year. You claim the RECs by completing an application form with the ORER (<http://www.orer.gov.au/>) You can claim RECs each year or in five year blocks, for the life of the system, or as a single one-off 15 year block. You can sell them to anyone who wants to buy them, eg. electricity suppliers. The ORER maintains a list of registered agents.

### **Retailers and Installers**

The Clean Energy Council ([www.bcse.org.au/default.asp?id=119](http://www.bcse.org.au/default.asp?id=119)) maintains a list of accredited installers throughout Australia.

### **Tasmania:**

Apollo Energy - Rob Wells, 110 Elizabeth St, Launceston 7250. Ph 6331 6119 or 0447 446 662. [rob.wells@apolloenergy.com.au](mailto:rob.wells@apolloenergy.com.au)

Brett Carter Solar Energy - Brett Carter, 166 Batchelors Rd, Nichols Rivulet 7112. Ph 6295 0842 / 0419 528 048  
[brett.carter@activ8.net.au](mailto:brett.carter@activ8.net.au)

Confac Electrical Services, 33 Dynnyrne Rd Dynnyrne 7005. Ph 0419 358 634  
[saverio.meale@confacelectrical.com.au](mailto:saverio.meale@confacelectrical.com.au)

Lorinna Energy Systems - Bart Wisse, PO Box 105 Sheffield 7306. Ph 6363 5070  
[lorensys@lorinna.net](mailto:lorensys@lorinna.net)

Mark the Spark - Mark Mather, PO Box 37 Snug 7054. Ph 6267 4121  
[markthesparky@bigpond.com](mailto:markthesparky@bigpond.com)

NUEnergy – Jess Reynolds, 4-6 Effingham St, Moonah 7009. Ph 6272 4366  
[enquiries@nuenergy.com.au](mailto:enquiries@nuenergy.com.au)

Powercom Systems Pty Ltd  
72 Browns Road, Kingston 7050. Ph 6229 7966. [catherine@powercomgroup.com](mailto:catherine@powercomgroup.com)

Residential Solar Systems - Laurence Port, 41 Tarroona Cres, Tarroona 7053. Ph 6227 8421, [laurenceport@hotmail.com](mailto:laurenceport@hotmail.com)

Solar Energy Direct – Joseph Askey-Doran  
150 Lollara Rd, Ranelagh 7109. Ph 6266 4395. [sales@solarenergydirect.com.au](mailto:sales@solarenergydirect.com.au)

Solar Tasmania - Noel Stutterd, PO Box 1013 Burnie 7320. Ph 6431 7733  
[solartas@hotmail.com](mailto:solartas@hotmail.com)

Southern Solar Electrical Services - Russell Thiessen, PO Box 58 Dover 7117. Ph 6298 3232/ 0438629838,  
[mayfly.hastings@tassie.net.au](mailto:mayfly.hastings@tassie.net.au)

Tasman Energy - Robert Sharman, PO Box 266 Deloraine 7304. Ph 6362 3050  
[tasen@bigpond.com](mailto:tasen@bigpond.com)

October 2008